

## SPECIFICATIONS

1. THERMOFORMED DOME MADE OF SINGLE/DOUBLE/TRIPLE LAYER PLASTIC (ACRYLIC OR POLYCARBONATE)
2. ALUMINIUM FIXING CLAMP - MILL FINISH (SCREW-FIXING VERSION AVAILABLE)
3. ALUMINIUM FRAMES - MILL FINISH (RAL COLORS PAINTING AVAILABLE)
4. FIXING SCREW
5. CHAIN ACTUATOR 230 V AC
6. EXISTING CURB OR UPSTAND
7. ALUMINIUM HINGE - MILL FINISH

Please note: Every item painted RED in this technical sheet must be considered pre-existing or at the expense of the customer.

ACTUATOR SIDE  
(CLOSING POSITION)

ACTUATOR SIDE  
(OPENING POSITION)

HINGES SIDE

## PARAMETERS

- A = DAYLIGHT OPENING
- B = MAX SUPPORT DIMENSION [A + 15 cm]
- C = OVERALL CURB SIZE: UP TO [A + 13 ÷ 15 cm] DIRECT INSTALLATION  
UP TO [A + 20 cm] DIRECT INSTALLATION (FLASHING RECOMMENDED)  
UP TO [A + 40 cm] FLASHING NEEDED
- D = FRAME INTERNAL SIZE [A + 5 cm]
- E = FRAME EXTERNAL SIZE [A + 13 cm]
- F = CENTER TO CENTER FASTENING DISTANCE [A + 9 cm]
- G = OVERALL DIMENSION [A + 20 cm]

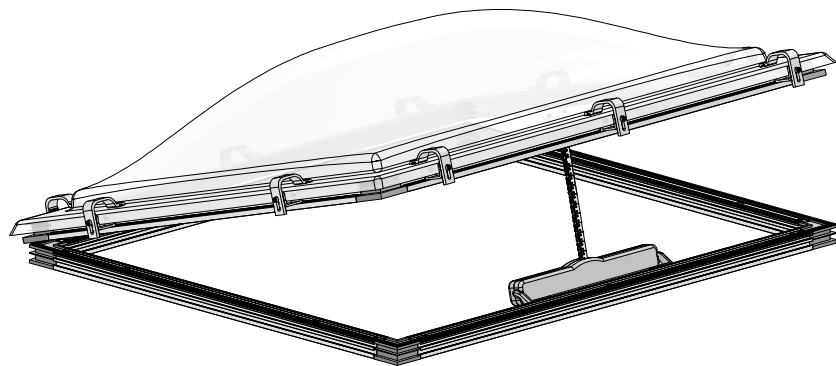

**TELFORM**

TELFORM NEW GENERATION srl

Via delle Mammole 22 - 70026 Modugno (BA - ITALY)  
TEL +39 080 5375656 FAX +39 080 5375098  
E-MAIL info@telform.it WEB www.telform.it

ELECTRIC SKYLIGHT

Scale 1 : 5	Format ISO A4	Description: CHAIN SPINDLE ACTUATOR
----------------	------------------	--

This drawing is the property of Telform NG srl and incorporates information which is proprietary. Publication and/or public distribution in whole or in part is expressly prohibited without the prior written consent of Telform NG srl. The information contained herein remains the property of Telform NG srl. All rights reserved.